



Along with our Eliminator, Vacuum Pumps and Boom Swivels, we also offer a range of related parts and accessories.



Driven. By Design



Toll Free: 1-800-663-9003
905-662-6552

www.fruitlandmanufacturing.com

324 Leaside Avenue, Stoney Creek, Ontario, L8E 2N7



Fruitland® Pumps are renowned for their reliability, performance and ease of installation. The Fruitland™ brand is a reliable standard for many companies in a myriad of industries all over the world.

Rotary Vane Vacuum Pumps

Our **Rotary Vane Vacuum pumps** require minimal maintenance, use minimal oil and will provide years of reliable service. Our pumps are designed to tackle the toughest liquid waste applications including; Oil & Gas, Environmental, Industrial, Septic, Grease and any other Liquid Waste.

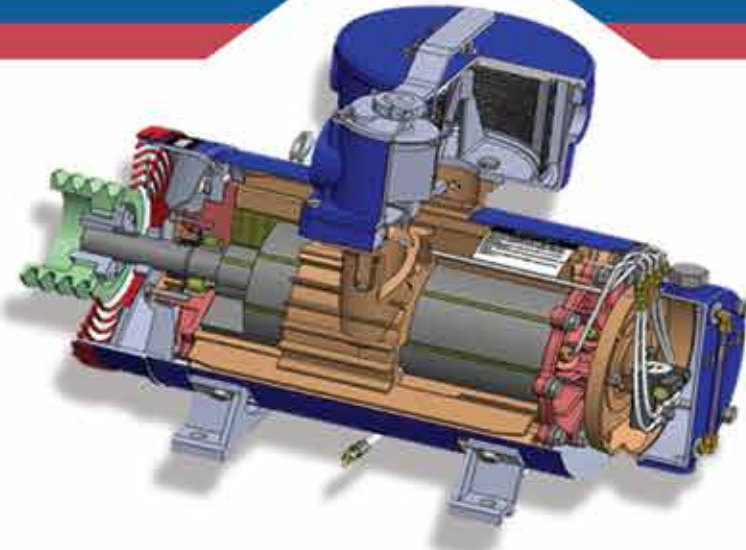

The Fruitland® Family of Vacuum Pumps

- Integral automated lubrication system
- Low oil consumption
- Clockwise or counter clockwise rotation
- Optional air intake filter
- Belt, direct, hydraulic or angle drives
- Vane wear check ports
- Top or side mount 4-way valves available
- Air cooled
- 2 year warranty

Vacuum Pump General Specifications

| Type | RCF250 | RCF370 | RCF500 | RCF870 | RCF1200 |
|-------------------------|--------------|---------------|---------------|---------------|---------------|
| Free Air Flow | 198 CFM | 293 CFM | 396 CFM | 512 CFM | 942 CFM |
| Maximum Vacuum/Pressure | 27" Hg/30psi | 28.5 Hg/35psi | 28.5 Hg/35psi | 28.5 Hg/30psi | 28.5 Hg/35psi |
| Sizes of Hoses | 2" | 3" | 3" | 4" | 4" |
| Maximum Operating Speed | 1400 RPM | 1400 RPM | 1400 RPM | 1400 RPM | 1000 RPM |
| Vaness | 4 (kevlar) | 8 (kevlar) | 8 (kevlar) | 8 (kevlar) | 8 (kevlar) |
| Air flow at 18" Hg | 150 CFM | 259 CFM | 320 CFM | 320 CFM | 617 CFM |
| Approx. Weight | 255 LBS | 385 LBS | 450 LBS | 575 LBS | 1400 LBS |

Data subject to change without notice

Eliminator Series

The **Fruitland Eliminator Series** offers the reliability of the **Fruitland Pump**, combined with the ease and simplicity of our **Ready2Rig** pump mounts. We offer several design options including heavy duty pump stands, secondary shutoffs, mufflers, angle drive, gearbox and hydraulic drive options. Tailor your Eliminator package to your specific needs and enjoy effortless installation combined with the power and durability of Fruitland.



The **READY2RIG** Eliminator Series

Available for all Vacuum Pumps

An integrated package that is easy to install for most applications.

An integrated commercial duty package available in angle, belt, diesel and hydraulic drives designed and built to meet your vacuum requirements.

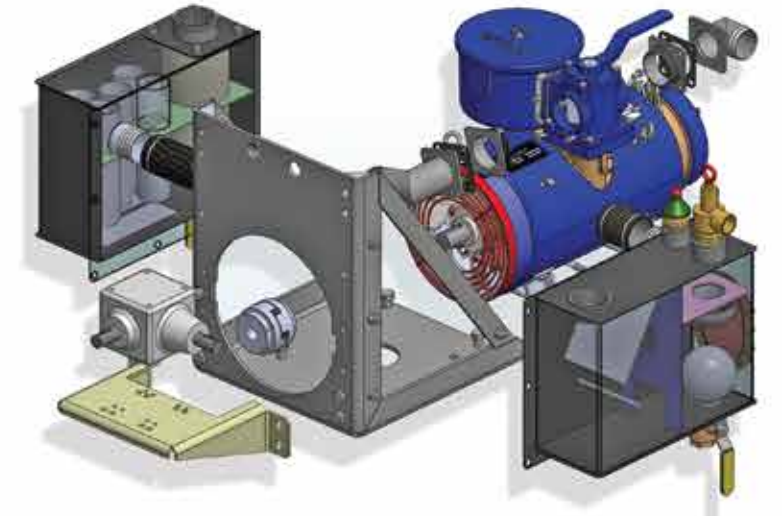

Installation as Easy as 1, 2, 3!

- 1. Bolt it to the truck or trailer frame**
- 2. Connect drive and plumbing**
- 3. Begin loading and unloading**



Fruitland Manufacturing has an integral quality management system which is registered to ISO 9001:2008 with BSI