

- NOTES:
 - MAX. CAPACITY: 40.3 kNm
 29,723LB-FT
 - MAX. RACEWAY VELOCITY: 50 FT/MIN
 - BALL RACE FLAME HARDENED
 - FOR FASTENERS USE GRADE 8 BOLTS

CUSTOMER COPY
 GENERAL INFORMATION ONLY

REVISIONS			
REV.	DESCRIPTION	DATE	APPROVED
1	ITEM 3 BEARING BALLS QTY 68 WAS 64	11/23/05	WALTER
2	CAPACITY CORRECTED	01/17/07	HANS

INNER RING

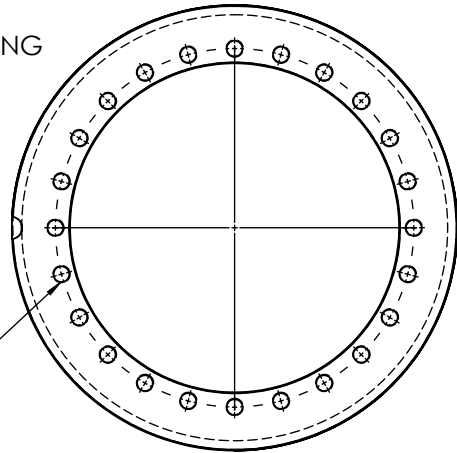

5/8" NC X 1.2" ∇
 24 HOLES EQ. SP.
 ON \varnothing 13.07" B.C.

OUTER RING

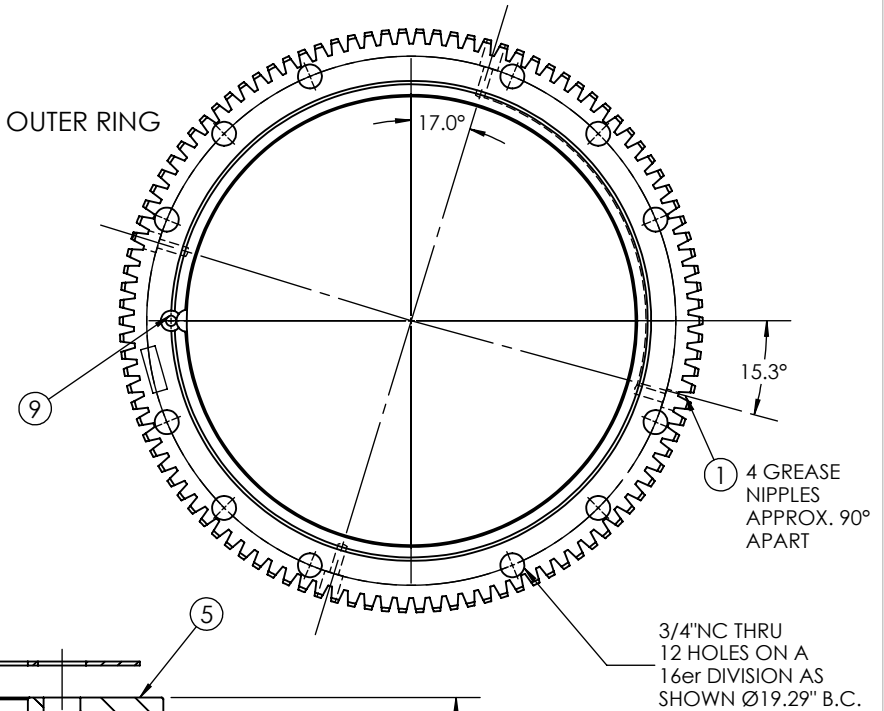

① 4 GREASE NIPPLES
 APPROX. 90°
 APART

3/4"NC THRU
 12 HOLES ON A
 16 σ r DIVISION AS
 SHOWN \varnothing 19.29" B.C.

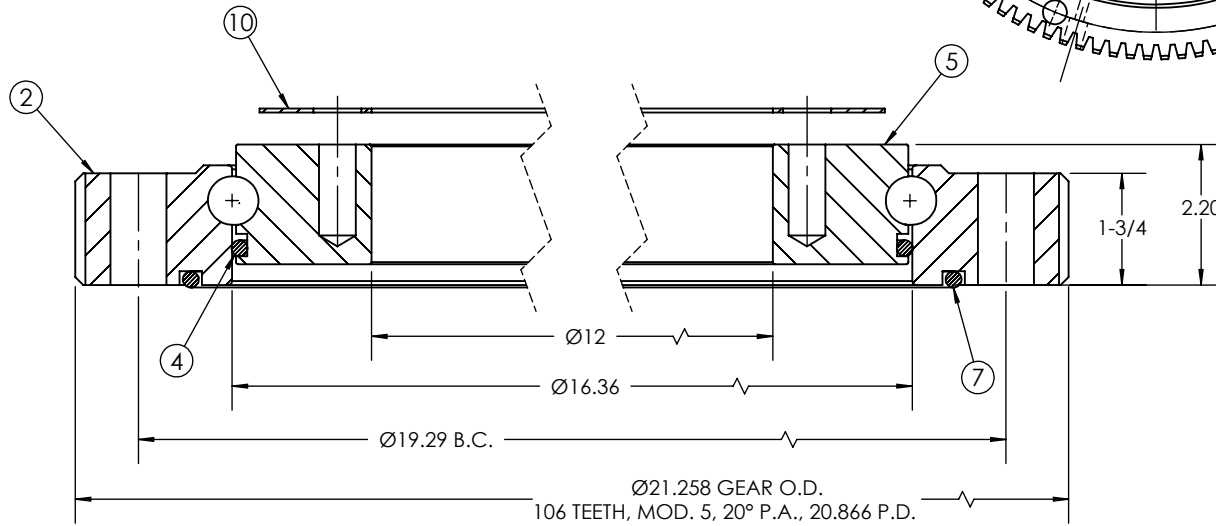

FM RESERVES THE RIGHT
 TO MAKE CHANGES
 WITHOUT NOTICE

ITEM #	DESCRIPTION	PART #	QTY.
1	GREASE NIPPLE 1/8" NPT	BS8"-1	4
2	GEARED OUTER RING	BS12"G-2	1
3	BEARING BALL (CHROMED ALLOY STEEL)	B 3/4"	68
4	"O" RING BUNA N (0.250 ACT. DIA SECT.)	BS12"-4	1
5	INNER RING	BS12"-5	1
7	BOTTOM "O" RING (0.250 ACT. DIA SECT.)	BS12"-7	1
9	3/8" X 5.8" LG. SOC.FL.HD.SCREW	BS17"-9	1
10	GASKET 1/16" TH.	12IDGAS	1

MAT'L: C-1045

PART# BS12"G

PROPRIETARY AND CONFIDENTIAL
 THE INFORMATION CONTAINED IN THIS
 DRAWING IS THE SOLE PROPERTY OF
 FRUITLAND MANUFACTURING. ANY
 REPRODUCTION IN PART OR AS A
 WHOLE WITHOUT THE WRITTEN
 PERMISSION OF FRUITLAND MFG. IS
 PROHIBITED.

NAME	DATE		324 Leaside Avenue Stoney Creek, Ontario, CANADA L8E 2N7 Phone: (905) 662-6552 Fax: (905) 662-5412	
CREATED	F.H. 03/10/13		TITLE:	12" GEARED ROTATING SEAL
CHECKED		UNLESS OTHERWISE SPECIFIED: DIMENSIONS ARE IN INCHES TOLERANCES: FRACTIONAL OR .X = \pm 0.015 .XX = \pm 0.010 .XXX = \pm 0.005	DWG. NO.	REV
MATERIAL	--	SCALE: 1:7 & 1:3	12G.CUC	2
		WEIGHT:--		