

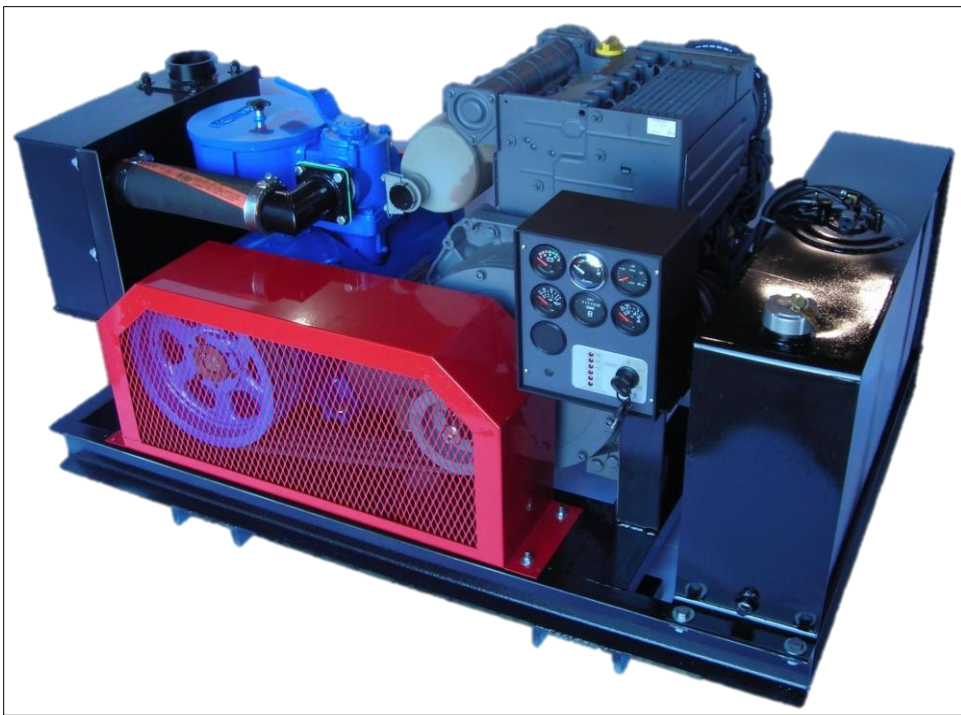

Fruitland **READY2RIG**

Eliminator Series



The Eliminator diesel (Elim D) is a unique blend of power and independence. Ideally suited for applications where remote vacuum is essential. The Elim D is skid mounted and ready for most location applications including under tank trailer frames (belly mount). The Elim D is designed for 16 hours of continuous operation.

Part # Elim D

- Includes a Diesel Engine and our RCF 500 LUF Vacuum Pump
- Easy to Install
- Strong Durable Components
- Powder Coated Finish
- Weight-1630 lbs.
- 350 CFM

Special Features of the Elim D

- *Includes RCF500 LUF Vacuum Pump
- *20US Gal. Diesel Fuel Tank (76 Liter)
- *LOFA Analog Control Panel with Electric Fuel Gauge
- *Deutz Diesel Engine (46 HP @2800 RPM)
- *M09 High Efficiency Oil Catch Muffler
- *12V Battery

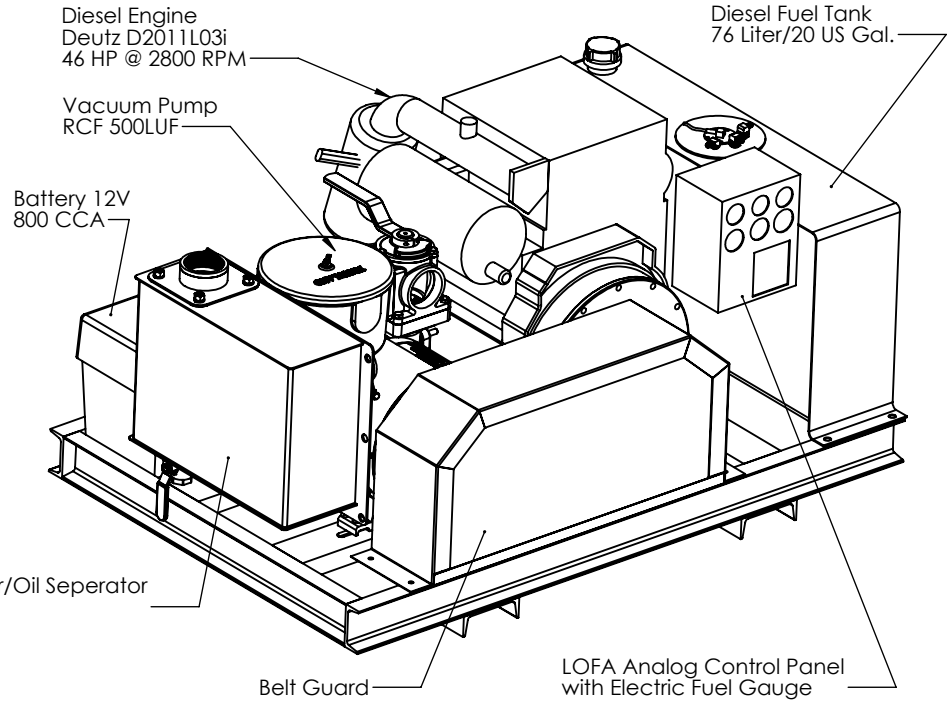
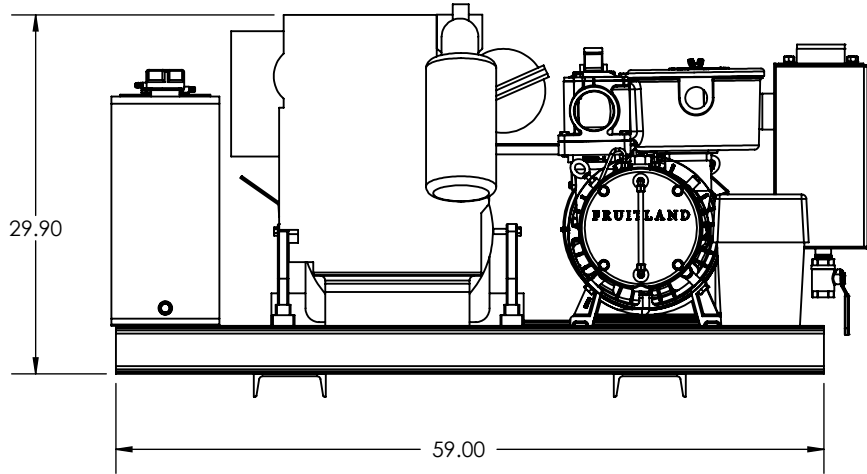
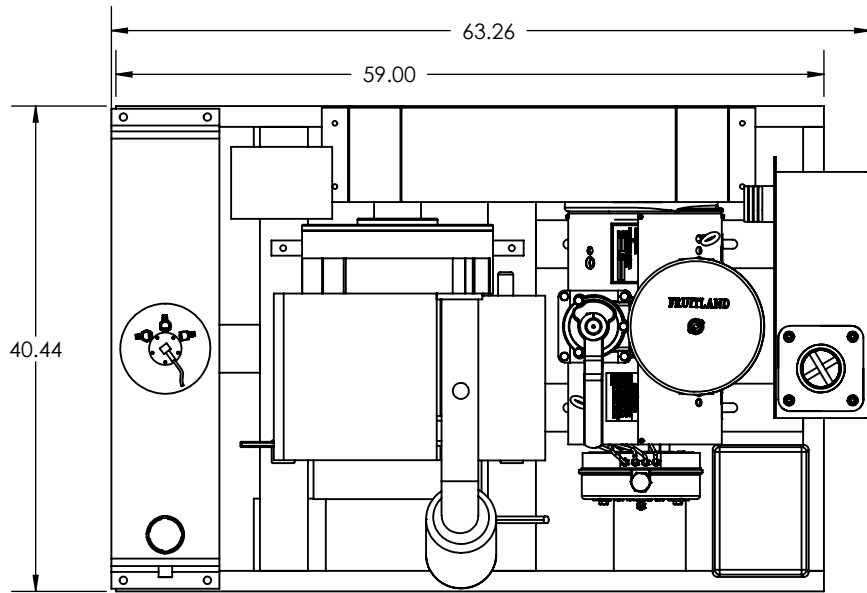

Part # Elim D

FOR GENERAL INFORMATION ONLY

PROPRIETARY AND CONFIDENTIAL
 THE INFORMATION CONTAINED IN THIS DRAWING IS THE SOLE PROPERTY OF FRUITLAND MANUFACTURING. ANY REPRODUCTION IN PART OR AS A WHOLE WITHOUT THE WRITTEN PERMISSION OF FRUITLAND MFG. IS PROHIBITED.

| | | | | | |
|---|------|----------|---|--|--------------|
| | NAME | DATE |  | 324 Leaside Avenue Stoney Creek, Ontario, CANADA L8E 2N7 Phone: (905) 662-6552 Fax: (905) 662 9875 | |
| CREATED | K.A. | 3/4/2013 | | TITLE: | Elim Diesel |
| CHECKED | | | DWG. NO. | Elim D | REV 0 |
| UNLESS OTHERWISE SPECIFIED: DIMENSIONS ARE IN INCHES TOLERANCES: FRACTIONAL OR .X = ±.015 .XX = ±.010 .XXX = ±.005 | | | SCALE: 1:16 | WEIGHT:-- | SHEET 1 OF 1 |
| MATERIAL | -- | | | | |

5

4

3

2

1