

ELIMINATOR TB
Top Frame Mount Belt Drive
For RCF 500 Pumps

Part # TFM-11R (Sold with regular installation kit)

Part # TFM-11M (Sold with Mack truck Installation kit)



#	Part Number	Description	Qty.	Price
1	500-LUF	Vacuum Pump	1	
2	TFM-11-01	Top Frame Mount Base	1	
3	TFM-11-02	Top Mount Shaft Bracket	1	
4	TFM-11-BG	Top Mount Belt Guard	1	
5	TFM-11-08	Jack Shaft, Ø 1 3/4", 3/8" keyway	1	
6	TFM-11-A1	1 3/4" Pillow Block Bearings w collar	2	
7	TFM-11-A2	B78 (or BX78) V Belt	4	
8	RF-500-38	4 Groove, 6" Sheave	2	
9	TFM-11-11	1-3/4"Ø SK BUSHING	1	
14	TFM-11-07	Shaft Adjustment Bracket	2	
15	5/8"x2" HEX Head	5/8" NC 2" Long Zinc Plated Hex Head Bolts	4	
15a	5/8"x2.25" HEX Head	5/8" NC 2.25" Long Zinc Plated Hex Head Bolts	4	
16	5/8" F/W-USS	5/8" Zinc Plated Flat Washer, Large	4	
16a	5/8" F/W-SAE	5/8" Zinc Plated Flat Washer, Small	8	
17	5/8" L/W	5/8" Lockwasher	12	
18	5/8" Nut	5/8" Zinc Plated NC Hex Nuts	12	
19	5/8"x2.5" HEX Head	5/8" NC 2.5" Long Zinc Plated Hex Head Bolts	4	
20	1/2"x 3.25" Hex Head	1/2" NC 3.25" Long Zinc Plated Hex Head Bolts	2	
21	1/2" Flat Washer	1/2" Zinc Plated Flat Washer	4	
22	1/2" L/W	1/2" Lockwasher	2	
23	1/2" Nut	1/2" Zinc Plated NC Hex Nuts	2	
24	RF500-67A	10mm Hex Head Bolt 10x1.5x30	4	
25	RF500-308	10mm Plain Washer	8	
26	RF500-137A	10mm Hex Nut	4	
27	RF120-94A	10mm Lock Washer	4	
28	SK 42	Taper Bushing 42mm	1	

Regular Installation Kit

10	TFM-11-A3	3-1/2" U Bolt, Ø5/8-11 NC	4	
11	TFM-11-09	Tie Bar Plates for 3-1/2" U Bolts	4	
16	5/8" F/W-USS	5/8" Zinc Plated Flat Washer, Large	8	
17	5/8" L/W	5/8" Lockwasher	8	
18	5/8" Nut	5/8" Zinc Plated NC Hex Nuts	8	

Mack Truck Installation Kit

12	TFM-11-A4	4-3/16" U Bolt Ø5/8-11 NC for Mack Only	4	
13	TFM-11-A5	Tie Bar Plates for 4-3/16" U Bolts Mack Only	4	
16	5/8" F/W-USS	5/8" Zinc Plated Flat Washer, Large	8	
17	5/8" L/W	5/8" Lockwasher	8	
18	5/8" Nut	5/8" Zinc Plated NC Hex Nuts	8	

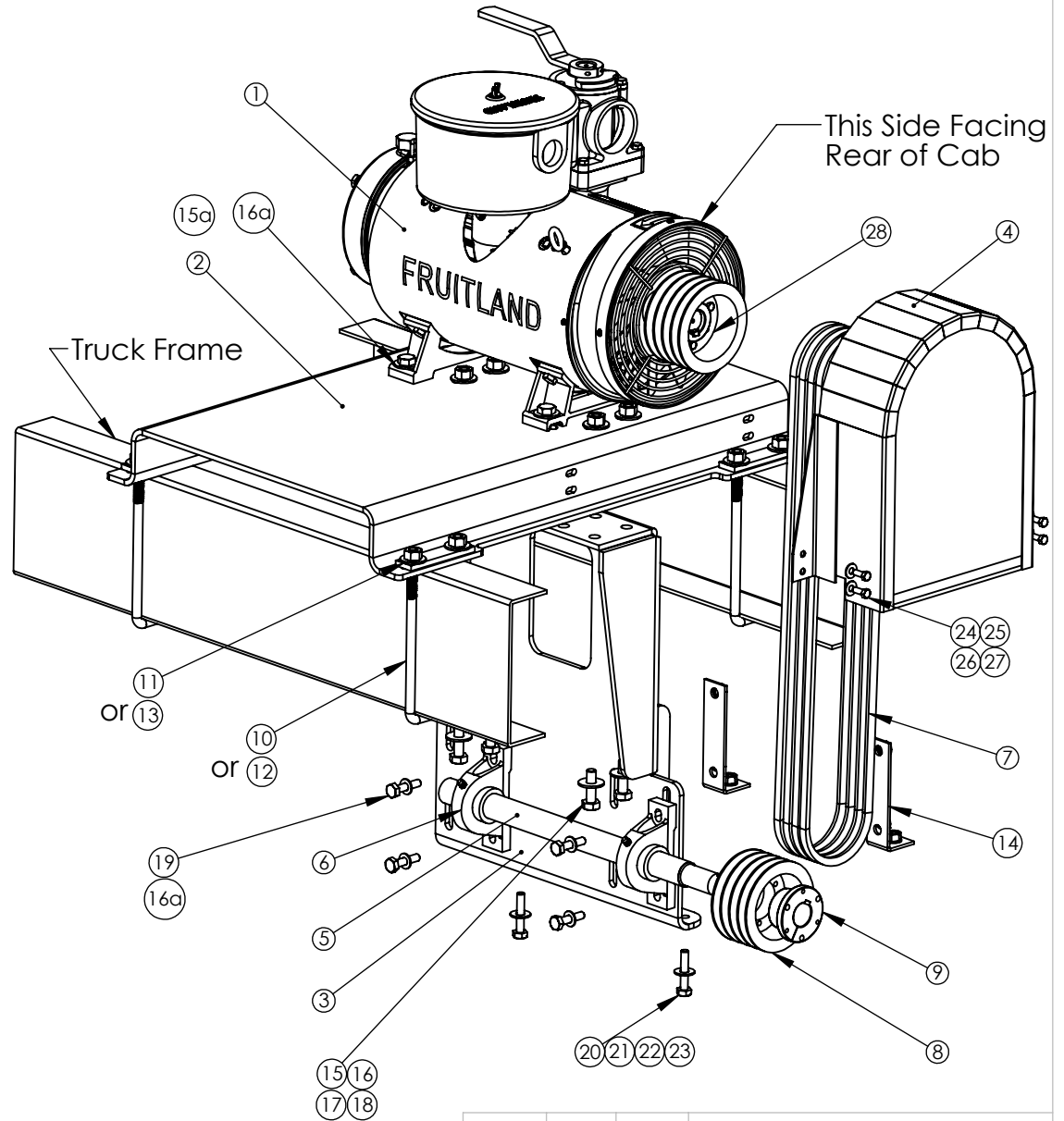

PROPRIETARY AND CONFIDENTIAL
 THE INFORMATION CONTAINED IN THIS DRAWING IS THE SOLE PROPERTY OF **FRUITLAND TOOL AND MFG.** ANY REPRODUCTION IN PART OR AS A WHOLE WITHOUT THE WRITTEN PERMISSION OF FRUITLAND TOOL AND MFG. IS PROHIBITED.

	NAME	DATE	FRUITLAND TOOL & MFG. 324 Leaside Ave., Stoney Creek Ontario, CANADA Phone: (905) 662-6552 Fax: (905) 662 9875	
DRAWN	K.A.	9/9/2011	TITLE: Top Frame Mount Belt Drive	
CHECKED				
UNLESS OTHERWISE SPECIFIED: DIMENSIONS ARE IN INCHES TOLERANCES: FRACTIONAL OR .X = ±.015 .XX = ±.010 .XXX = ±.005			DWG. NO. TFM-11-BOM	REV 1
MATERIAL	--		SCALE: 1:12	WEIGHT:--
			SHEET 1 OF 1	

Rev. 1, DCR # 441 Renamed Package part number.