

-MAX. CAPACITY: 72.62 kNm
53,560 LB-FT FORCE

- MAX RACEWAY VELOCITY: 50FT/MIN
- HEAT TREATED RACEWAYS
- USE GRADE 8 FASTENERS AND LOCKWASHERS
- MAT'L: C-1045

CUSTOMER COPY
FOR GENERAL INFORMATION ONLY

REVISIONS				
DCR	REV.	DESCRIPTION	DATE	APPROVED
267	1	ITEM 3 BEARING BALLS QTY WAS 85, DWG# & COMP.FILE# CORRECTED	11/22/05	HANS
339	2	GREASE NIPPLE POSITION NOW SPECIFIED	05/01/09	ERIC
414	3	BALL QTY WAS 89. ITEM# 26 ADDED 72 NYLON SPACERS	05/30/11	ERIC
	4	ADDED ITM.4 WIPER SEAL. NYLON SPACER REMOVED, BALL QTY=72	10/9/2018	K.A.
	5	BOM UPDATED, NO PHYSICAL CHANGES	10/10/2023	I.P.

CAN ALSO BE INSTALLED UPSIDE DOWN

INNER RING

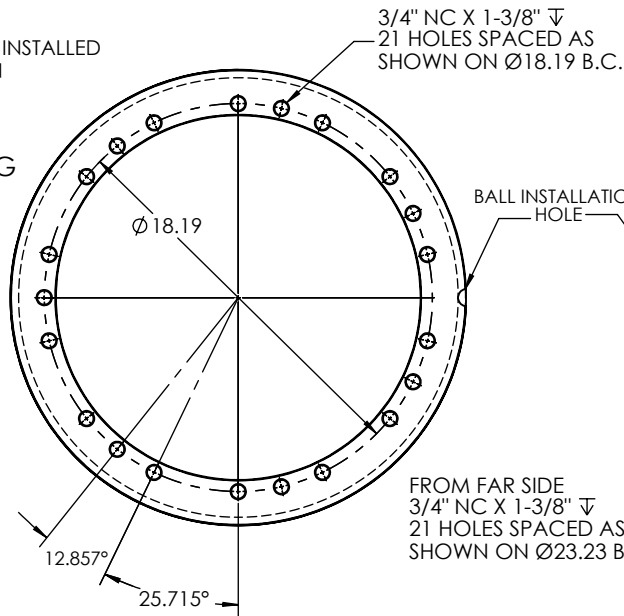

3/4" NC X 1-3/8" ∇
21 HOLES SPACED AS SHOWN ON \varnothing 18.19 B.C.

OUTER RING

BALL INSTALLATION HOLE

FROM FAR SIDE
3/4" NC X 1-3/8" ∇
21 HOLES SPACED AS SHOWN ON \varnothing 23.23 B.C.

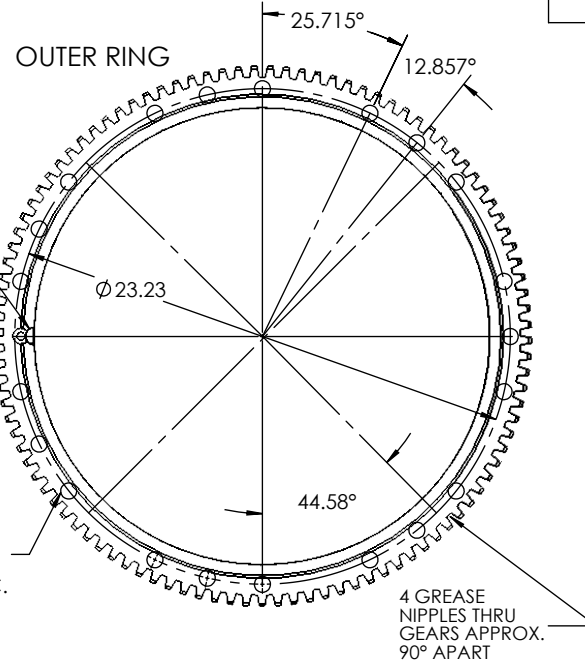

4 GREASE NIPPLES THRU GEARS APPROX. 90° APART

ROTATING SEAL

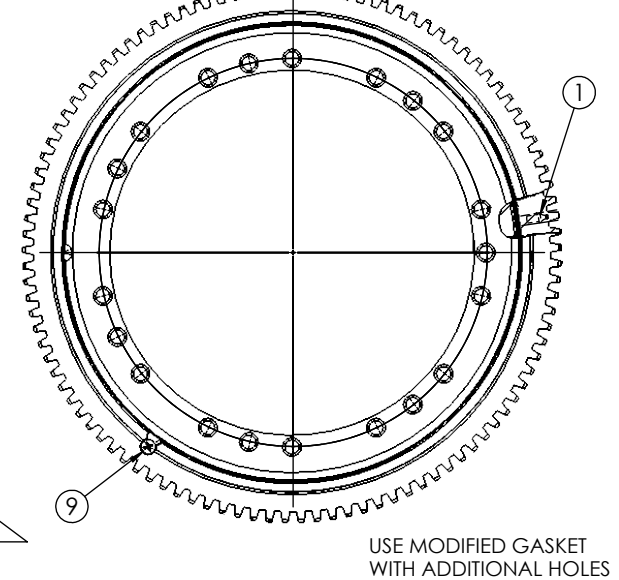

USE MODIFIED GASKET WITH ADDITIONAL HOLES

THIS UNIT IS THE SAME AS THE REGULAR 17" GEARED ROTATING SEAL, WITH THE EXCEPTION OF THE MODIFIED BOLT HOLE PATTERNS

(SEE RECORDS 41 & 42 IN DATABASE "BOLT CIRCLE PATTERN")

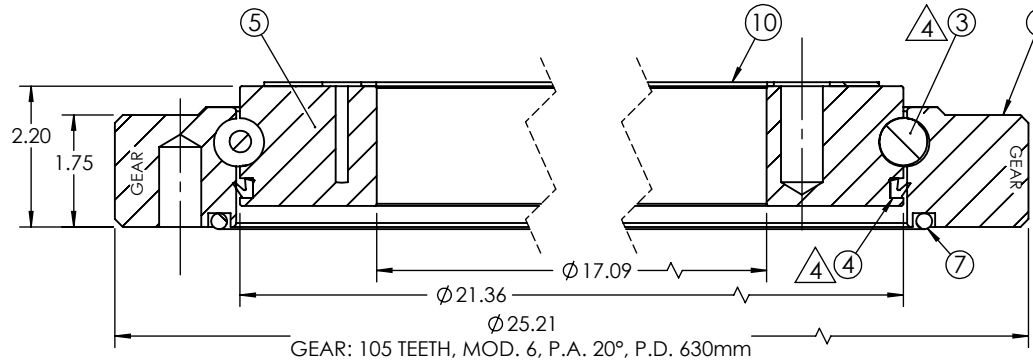

GEAR: 105 TEETH, MOD. 6, P.A. 20°, P.D. 630mm

17" GEARED BOOM SWIVEL FOR HIGH CAPACITY
PART# BS17GHC

FRM RESERVES THE RIGHT TO MAKE CHANGES WITHOUT NOTICE

ITEM #	PART #	DESCRIPTION	QTY.
1	BSX-125-N	GREASE NIPPLE (w/ BALL) - 1/8" NPT	4
2	BS17-ORGHC	17" GEARED OUTER RING FOR HIGH CAPACITY	1
3	BSB-75	BEARING BALL - \varnothing 3/4"	72
4	BS17-4-OR	INNER RING O-RING - BUNA N (0.250 ACT. DIA SECT.)	1
5	BS17ORGHC	17" INNER RING FOR HIGH CAPACITY	1
7	BS17-7-ORG	BOTTOM O-RING (0.250 ACT. DIA SECT.)	1
9	HBI-380-627	F.H.C.S - 3/8"-16 NC x 5/8" LONG	1
10	17GAS	GASKET - 1/16" THK.	1

4

PROPRIETARY AND CONFIDENTIAL
THE INFORMATION CONTAINED IN THIS DRAWING IS THE SOLE PROPERTY OF FRUITLAND MANUFACTURING. ANY REPRODUCTION IN PART OR AS A WHOLE WITHOUT THE WRITTEN PERMISSION OF FRUITLAND MFG. IS PROHIBITED.

NAME	DATE	FRUITLAND	
CREATED	S.P. 03/19/2013	324 Leaside Avenue Stoney Creek, Ontario, CANADA L8E 2N7 Phone: (905) 662-6552 Fax: (905) 662-9875	
CHECKED	K.A. 10/10/2018	TITLE: 17" GEARED BOOM SWIVEL FOR HIGH CAPACITY - CUSTOMER COPY	
UNLESS OTHERWISE SPECIFIED: DIMENSIONS ARE IN INCHES TOLERANCES: FRACTIONAL OR .X = ±.015 .XX = ±.010 .XXX = ±.005		DWG. NO. BS17GHC-CC	REV 5
MATERIAL	--	SCALE: 1:9	WEIGHT:--

5

4

3

2

1