

RCF500 oil pumps come pre adjusted from the factory and rarely require any adjustment during their life time. However if a need arise, the following procedure should be followed to adjust the oil flow rate.

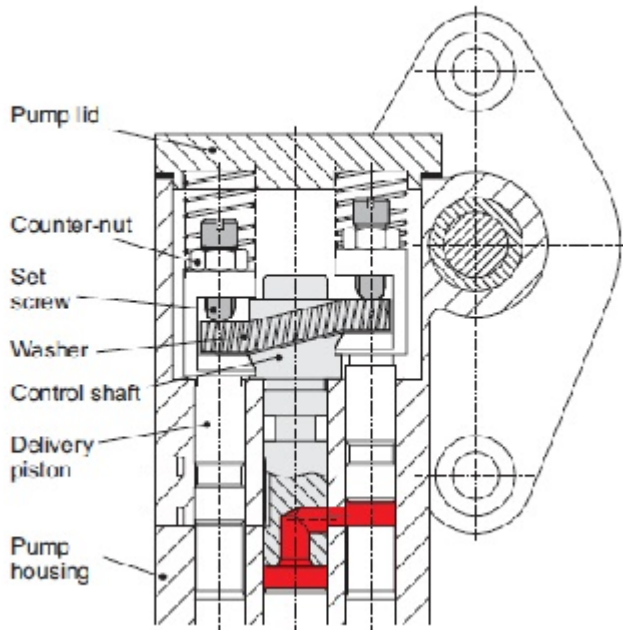

Oil Rate Adjustment:

The delivery strokes are adjusted with the set screws under the pump lid and that regulates the output rate. Turning the set screw to the right increases the output rate, turning to the left reduces it.

To adjust the output rate, take off the pump lid, loosen the counter-nut, use the set screw to adjust the rate, tighten the counter-nut and fix the pump lid again. The volume can be reduced down to 30 % of the max. output rate without effecting the pump's function.

One turn of the set screw reduces the output by 1/3 of the total delivery volume.

Please only adjust the delivery volume after putting into operation and a complete air discharge of the pressure connection.

Quick Summary:

- Remove pump lid
- Loosen Counter Nut
- Rotate adjusting screw as shown in figure
- A gap of 0.05" should be maintained between the screw and the washer for correct flow rate

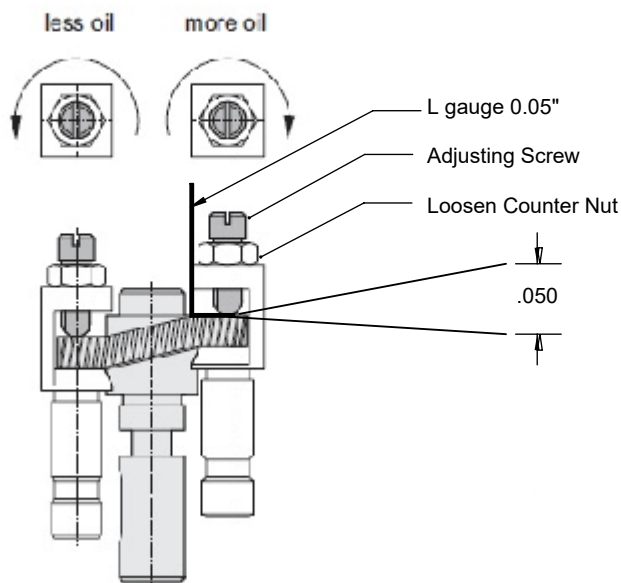

Due to space limitations, a custom designed small L shaped feeler gauge of 0.05" is needed to adjust the gap.

With this adjustment the oil flow rate is approx. 1 liter in 4 hours for RCF 500 Pump.