

PART # ELIM G172L

PROPRIETARY AND CONFIDENTIAL
 THE INFORMATION CONTAINED IN THIS DRAWING IS THE SOLE PROPERTY OF FRUITLAND MANUFACTURING. ANY REPRODUCTION IN PART OR AS A WHOLE WITHOUT THE WRITTEN PERMISSION OF FRUITLAND MFG. IS PROHIBITED.

	NAME	DATE		324 Leaside Avenue Stoney Creek, Ontario, CANADA L8E 2N7 Phone: (905) 662-6552 Fax: (905) 662-5412	
CREATED	Z.D.	08/29/2019		TITLE:	ELIM G172L BOM
CHECKED	K.A.	08/29/2019	DWG. NO.	ELIM G172L - BOM	REV P4
UNLESS OTHERWISE SPECIFIED: DIMENSIONS ARE IN INCHES TOLERANCES: FRACTIONAL OR .X = ±.015 .XX = ±.010 .XXX = ±.005			MATERIAL	--	SCALE: WEIGHT:-- SHEET 1 OF 2

ITEM#	PART #	DWG #	DESCRIPTION	QTY.
1	172L		RCF172 VACUUM PUMP	1
2	FX420		FRUITLAND 15 HP GAS ENGINE, ELECTRIC START	1
3	ELIM-G344-01	ELIM-G344-01	ELIM G344 BASE FRAME ASSEMBLY	1
4	ELIM-G250-02	ELIM-G250-02	ELIM G250 BELT GUARD	1
4A	ELIM G344-024	ELIM G344-024	G344 BELT GUARD WIRE MESH	1
5	RF344-1.5NPT-2BARB		1.5" NPT - 2" HOSE BARB CONNECTOR	2
5A	CVSP-3100-1.5"FM90		STREET ELBOW 90° 1.5" NPT MALE FEMALE	2
6	SF1.25	PURCHASED	SF BUSHING FOR Ø 1.25" SHAFT, 1/4" KEY	1
7	2B12.4L	2B12.4L	SHEAVE 12.4 SF 2 GROOVE B SECT.	1
8	SK1.0	PURCHASED	SK BUSHING FOR Ø 1" SHAFT, 1/4" KEY	1
9	2B6.0	2B6.0	6" SHEAVE 2 GROOVE B SECT.	1
10	ELIM-G250-03		BX55 V-BELT	2
11	ELIM-G250-04		BATTERY	1
12	ELIM-G250-06	ELIM-G250-06	BATTERY FRAME	1
13	ELIM-G250-041	ELIM-G250-041	BATTERY HOLD DOWN CLAMP	1
14A	ELIM-G250-042		8 GA BATTERY WIRE BLACK, 16" LG.	1
14B	ELIM-G250-043		8 GA BATTERY WIRE RED, 14" LG.	1
14C	ELIM-G250-044		8 GA COPPER EYELET	2
14D	ELIM-G250-045		BATTERY TERMINAL BOOT BLACK	1
14E	ELIM-G250-046		BATTERY TERMINAL BOOT RED	1
14F	ELIM-G250-047		STARTER SOLENOID TERMINAL BOOT RED	1
15	250-DSF-IN	250-DSF	250 DIVERTER SPACER FLANGES (1" THICK)-INTAKE	1
16	250-DSF-EX	250-DSF	250 DIVERTER SPACER FLANGES (1" THICK)-EXHAUST	1
17	RF250-238		DIVERTER INTAKE FLANGE GASKET	2
18	RF250-251		DIVERTER EXHAUST FLANGE GASKET	2

ITEM #	PART #	DWG #	DESCRIPTION	QTY
F1	1/2" X 1-1/2" HEX HEAD		1/2" NC 1-1/2" LONG ZINC PLATED HEX HEAD BOLTS	4
W1	1/2" F/W-USS		1/2" ZINC PLATED FLAT WASHERS, LARGE	4
W2	1/2" F/W-SAE		1/2" ZINC PLATED FLAT WASHERS, SMALL	4
N1	1/2" NYLOCK NUTS		1/2" NC NYLOCK HEX NUT	4
F2	3/8" X 2"		3/8" NC 2" LONG ZINC PLATED HEX HEAD BOLTS	4
W3	3/8" F/W-USS		3/8" ZINC PLATED FLAT WASHERS, LARGE	4
W4	3/8" F/W-SAE		3/8" ZINC PLATED FLAT WASHERS, SMALL	4
N2	3/8" NYLOCK NUTS		3/8" NC NYLOCK HEX NUT	4
F4			5/16"NC 1" LONG FLAX FLANGE SERRATED BOLTS	1
F5	5/16"X1" HEX BOLT		5/16" NC 1" LONG ZINC PLATED HEX HEAD BOLTS	6
W5	5/16"WASHER		5/16" ZINC PLATED FLAT WASHERS	12
N3	5/16" NYLOCK NUTS		5/16" NC NYLOCK HEX NUT	6
F7			M10x1.5x70mm SHCS (70mm LONG)	4
L1	RF120-94A		10mm LOCK WASHER	4
PR			ALUMINUM BLIND RIVET WITH BSTEEL MANDREL, LARGE DIAMETER DOMED HEAD, 3/16" DIA., for 0.126"-0.25" MATERIAL THICKNESS	15

PART # ELIM G172L

REV. P1. ENGINE CHANGED FROM GX260 TO GX390. 7-14-20. _____ E.A.
 REV. P2. BASE FRAME ASSEMBLY UPDATED. _____ 7-29-20. I.D.
 REV. P3. UPDATED BOM (ITEM#2). _____ 8-31-20. I.D.
 REV. P4. UPDATED BOM. ADDED SECOND SHEET. UPDATED TITLE BLOCK. 11/23/20. I.D.

	NAME	DATE		324 Leaside Avenue Stoney Creek, Ontario, CANADA L8E 2N7 Phone: (905) 662-6552 Fax: (905) 662-5412	
CREATED	Z.D.	08/29/2019		TITLE:	ELIM G172L BOM
CHECKED	K.A.	08/29/2019	DWG. NO.	ELIM G172L - BOM	REV P4
UNLESS OTHERWISE SPECIFIED: DIMENSIONS ARE IN INCHES TOLERANCES: FRACTIONAL OR .X = ±.015 .XX = ±.010 .XXX = ±.005			SCALE:	WEIGHT:-	SHEET 2 OF 2
MATERIAL	--				

PROPRIETARY AND CONFIDENTIAL
 THE INFORMATION CONTAINED IN THIS DRAWING IS THE SOLE PROPERTY OF FRUITLAND MANUFACTURING. ANY REPRODUCTION IN PART OR AS A WHOLE WITHOUT THE WRITTEN PERMISSION OF FRUITLAND MFG. IS PROHIBITED.

ELIM G172L

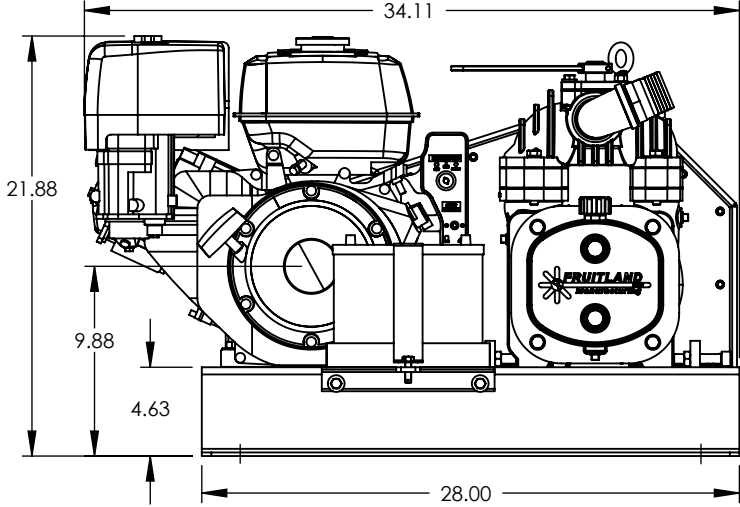
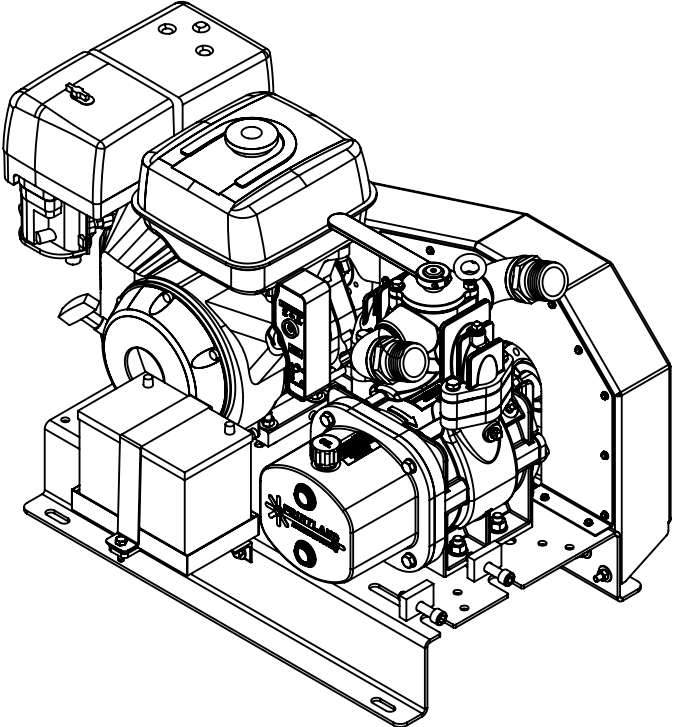
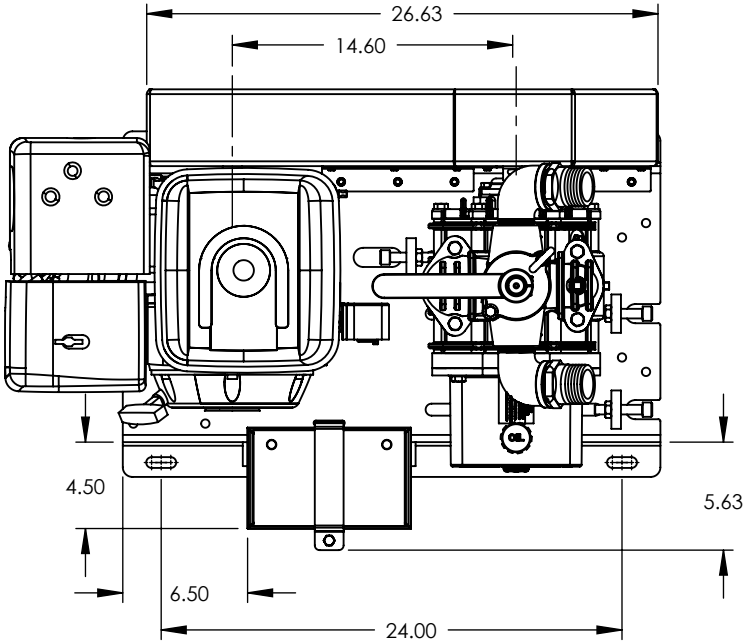
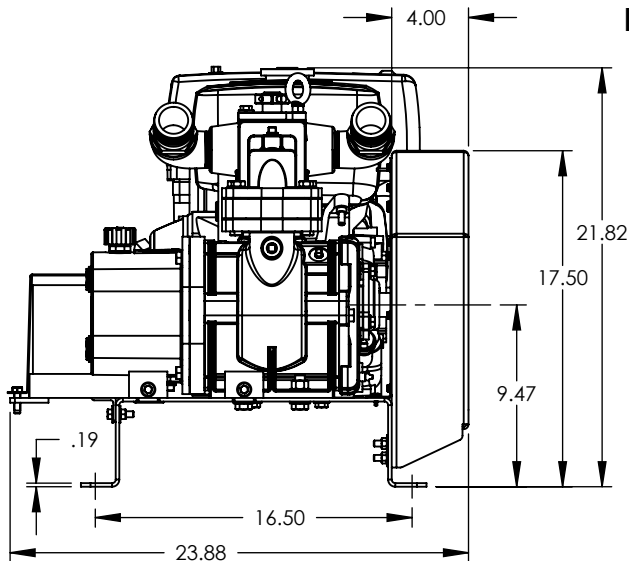

REV. P1: ENGINE CHANGED FROM GX260 TO GX390, 7-14-20, K.A.
 REV. P2: BASE FRAME ASSEMBLY UPDATED, 7-29-20, J.D.
 REV. P3: UPDATED BOM (ITEM#2), 8-31-20, J.D.
 REV. P4: UPDATED BOM, 11/23/20, J.D.

PROPRIETARY AND CONFIDENTIAL
 THE INFORMATION CONTAINED IN THIS DRAWING IS THE SOLE PROPERTY OF **FRUITLAND MANUFACTURING**. ANY REPRODUCTION IN PART OR AS A WHOLE WITHOUT THE WRITTEN PERMISSION OF FRUITLAND MFG. IS PROHIBITED.

	NAME	DATE		324 Leaside Avenue Stoney Creek, Ontario, CANADA L8E 2N7 Phone: (905) 662-6552 Fax: (905) 662-5412	
CREATED	Z.D.	08/29/2019		TITLE:	ELIM G172L DIMS
CHECKED	K.A.	08/29/2019	DWG. NO.	ELIM G172L - DIMS	
UNLESS OTHERWISE SPECIFIED: DIMENSIONS ARE IN INCHES TOLERANCES: FRACTIONAL OR .X = ±.015 .XX = ±.010 .XXX = ±.005			SCALE:	WEIGHT:-	
MATERIAL	--				