

ITEM #	PART #	DESCRIPTION	QTY.
2	RF870-SC	Pedestal Frame	1
12	HDM14	Hydraulic Motor Mount	1
Hex Bolts			
F2	HBI-600-170	Hex Bolt - 5/8"-11 NC x 1-3/4" Long - Z.P.	4
Hex Nuts			
F7	5/8" NUT	Nylock Hex Nuts - 5/8"-11 NC - Z.P.	4
Flat Washers			
F8	5/8" F/W-SAE	Flat Washer, SAE (Small) - 5/8" - Z.P.	8
Spring Pins			
F13	1/4" X 1" LG SPLIT PIN	Split Pin - 1/4" x 1" Long	2

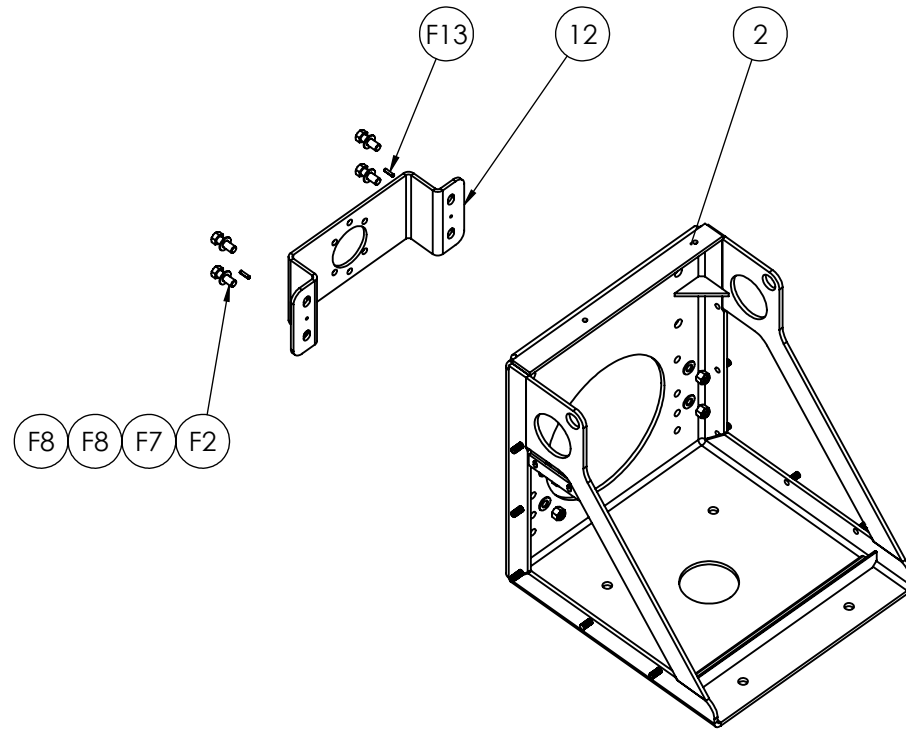

ELIMINATOR H PACKAGE
FOR 870 PUMPS
WITH HYDRAULIC MOTOR MOUNT

PART # ELIM870-H

NOTES:
1. ALL FASTENERS TO BE SUPPLIED.
2. WEIGHT AS SHOWN: 156 LBS

CUSTOMER COPY

NAME	DATE	 324 Leaside Avenue Stoney Creek, Ontario, CANADA L8E 2N7 Phone: (905) 662-6552 Fax: (905) 662 9875
CREATED	Z.D. 03/26/2015	
CHECKED	K.A. 03/26/2015	TITLE:
		ELIM870-H BOM
UNLESS OTHERWISE SPECIFIED: DIMENSIONS ARE IN INCHES TOLERANCES: FRACTIONAL OR .X = ±.015 .XX = ±.010 .XXX = ±.005		DWG. NO.
		ELIM870-H
MATERIAL		SCALE: 1:12
		WEIGHT:--
		REV
		1

PROPRIETARY AND CONFIDENTIAL
THE INFORMATION CONTAINED IN THIS DRAWING IS THE SOLE PROPERTY OF **FRUITLAND MANUFACTURING**. ANY REPRODUCTION IN PART OR AS A WHOLE WITHOUT THE WRITTEN PERMISSION OF FRUITLAND MFG. IS PROHIBITED.