

ITEM #	PART #	DRAWING #	DESCRIPTION	QTY.
1	EDH-870-01	EDH-870-01	ELIM DJ870 HATZ BASE FRAME	1
2	870LUF		870 VACUUM PUMP	1
3	ENGINE-3H50TIC	PURCHASED	HATZ DIESEL ENGINE	1
3A	ED-14-01		ELIM D (HATZ) MUFFLER EXTENTION	1
4	ED-12-A4		SK 1.5" BUSHING	1
5	RF500-38		6" SHEAVE 4 GROOVE B SECT.	1
6	SF42		TAPER PUMP BUSHING - 42mm BORE	1
7	5B12.4L		SHEAVE 12.4 SF 4 GR. B SECT.	1
8	ED-870-A1		BX71 V-BELT	4
9	EDS-BG0	EDS-BG0	ELIM D 500-870 HATZ BELT GUARD ASSM	1
10	EDF-19	FRUF3216	DIESEL FUEL TANK	1
11	RF870-M14	M14-BOM	MUFFLER M14	1
12	FL14	FL14	ELIM 870 4" FLANGE	1
13	RF870-65		DIVERTER GASKET FOR RF870	1
14	VB		1-1/2" VACUUM RELIEF VALVE	1
15	4" BLOWER HOSE		SRL-64 4" TANK HOSE (BLACK WITH BLUE STRIPE) , 15.25" LG.	1
16	MKL-121-SP		Ø4" HOSE CLAMP, MIKALOR M8 113-121mm	2
18	ED-12-A5		BATTERY	1
19	BATTERY BOX		BATTERY BOX	1
20	BATTERY KIT		BATTERY HOLD DOWN KIT	1
20A	ED-12-A6		BATTERY TERMINAL TOP	2
20B	ED-12-A7		4GA TUB LUG	2
20C	WIRE 4 AWG B		4AWG BLACK PVC BATTERY CABLE, 5 FEET LG.	1
20D	WIRE 4 AWG R		4AWG RED PVC BATTERY CABLE, 4 FEET LG.	1
21	ED-CP-01		HATZ CONTROL PANEL FOR AN ELIM DIESEL	1
22	EDF-12-A11		5/16" I.D. DIESEL FUEL HOSE 2FT	3
23	EDF-12-A12		5/16" HOSE CLAMP (CLIP)	5
24	RF870-AI		AIR INJECTION VALVE ASSEMBLY (FOR 870 PUMP)	1
25	1.25" NPT-BRB		BARBED FITTING 1.25 NPT -1.5 BARB HOSE	2
26	M14-AI		AIR INJECTION MUFFLER	1
27	M14-AI-B		AIR INJECTION MUFFLER BRACKET	2
28	AI-870-F		AIR INJECTION FILTER	1
29	1.5" HOSE EXFL		1.5" HOSE GOODYEAR PLICORD EXTREMEFLEX, 4" LG	1
30	1.5" HOSE EXFL		1.5" HOSE GOODYEAR PLICORD EXTREMEFLEX, 13" LG	1
31	1.5" HOSE CLIP		1.5" HOSE CLAMP, M8 HEX BOLT, 52-55mm	8
32	1.5" HOSE EXFL		1.5" HOSE GOODYEAR PLICORD EXTREMEFLEX, 26" LG.	1
33	AI-870-83		SS BRAIDED HOSE 1/4" NPT 14" LONG	1
34	AI-870-84		SS BRAIDED HOSE 1/4" NPT, 23" LONG	1
36	FPN-121-030-CS		NIPPLE 1-1/4" NPT 3.0" LG.	1
37	AI-870-5A		ELBOW 90 DEG. 1.25" NPT (FEMALE X FEMALE)	1
38	ED-21-BT	ED-21-BT	BELT TENSIONER PLATE ASSM	2
39	1/2" NPT PIPE PLUG		1/2" NPT PIPE PLUG	1
40	DBV31-B		1/4" BALL VALVE	1
41	RF250-32A		90° BRASS ELBOW 1/4" NPT MF	1
42	AI-870-81		BALL VALVE HOLDER HEX	1
43	AI-870-82		BALL VALVE HOLDER ROUND	1
46	INCL. WITH ENGINE		ELECTRIC FUEL PUMP	1
47	INCL. WITH ENGINE		FUEL PREFILTER	1
48	EDF-HOSE-ELBOW		ELBOW FOR ELIM D 2-3/4" ID 90 BLACK SIL. (HATZ)	1
48A	EDF-HOSE-JOINER		HOSE JOINER FOR ELIM D 2-3/4" ID BLACK SIL. (HATZ)	1
49	INCL. WITH ENGINE		AIR FILTER HOUSING (HATZ DIESEL)	1
50	EDF-HOSE		HOSE FOR ELIM D 2-3/4" ID BLACK SILOPHONE (HATZ)	1

ITEM#	PART#	DRAWING #	DESCRIPTION	QTY.
51	ED-16-01	ED-870-VBM-INST.	ELIM D MOUNTS, TWO PIECE RUBBER	4
52	ED-16-02	ED-870-VBM-INST.	ELIM D MOUNT REBOUND WASHER	8
53	ED-870-03	ED-870-VBM-INST.	SPACER FOR VIBRATION MOUNT ELIM-Ds	4
57			Ø2-3/4" HOSE CLAMP 2-1/2" TO 3-1/4" FASTENERS	4
F1	5/16" X 1" HEX BOLT		5/16" NC x 1" LG. Z.P. HEX BOLT	6
W1	5/16" WASHER		5/16" Z.P. FLAT WASHER	15
N1	5/16" NYLOCK NUTS		5/16" NC NYLOCK HEX NUT	9
F2	HNI-380-121		3/8" NC HEX HEAD BOLT, 1.25" LG.	2
W2	3/8" F/W-SAE		3/8" Z.P. FLAT WASHER - SMALL	6
W3	3/8" F/W-USS		3/8" Z.P. FLAT WASHER - LARGE	2
N2	3/18" NYLOCK NUTS		3/8" Z.P. NYLOCK HEX NUT	2
F3	1/2" X 1-1/2"		1/2" NC x 1-1/2" LG. Z.P. HEX BOLT	4
W4	1/2" FLAT WASHER		1/2" Z.P. FLAT WASHER	16
N3	1/2" NY-LOCK NUTS ZP		1/2" Z.P. NYLOCK HEX NUT	4
F4	HBI-620-301		5/8" NC x 3" LG. Z.P. HEX BOLT	4
N4	1/2" NUT		1/2" NC Z.P. HEX NUT	4
L1	1/2" L/W		1/2" LOCKWASHER	4
W5	5/8" F/W-USS		5/8" Z.P. FLAT WASHER - LARGE	4
W6	5/8" F/W-SAE		5/8" Z.P. FLAT WASHER - SMALL	8
N5	5/8" NYLOCK NUTS		5/8" Z.P. NYLOCK HEX NUT	4
F5	M8X16HEX		8mm HEX HEAD BOLT, 8x1.25x16	2
N6	HNM-080-H1		8mm HEX NUT	4
F6	RF500-67A		10mm HEX HEAD BOLT, 10x1.5x30	4
L6	RF120-94A		10mm LOCK WASHER	4
SB1	HBI-31H-623-380		3/8" x 5/8" WITH 5/16"-18 NC SHOULDER BOLT	4
RW1	ED-16-03A		ED FRAME RUBBER WASHERS	16
F7	HBI-620-172		7/8"-14 NF x 5.5" LG. HEX BOLT GRADE 8	4
N7	HNI-871-N1		7/8"-14 NF NYLOCK HEX NUT	4
RW2	ED-16-03		ED FRAME RUBBER WASHERS (1/2" THICK)	4
CS	EDF-19-A1		COMPRESSION SPRING	4
F8	HBI-501-352		1/2"-20 NF x 3-1/2" LG. Y.Z.P. HEX BOLT	4
N10	HNI-501-N2		1/2"-20 NF Y.Z.P. NYLOCK HEX NUT	4
N11	HNI-620-H1		5/8"-11 NC Z.P. HEX NUT	4

ELIM DH870LUF DIESEL HATZ BOM

PART# ELIM DH870LUF

DCR# 874, REV. 1, UPDATED BOM, 10/29/2020, I.D.
DCR# 916, REV. 2, UPDATED FRAME & BOM, 08/23/2021, I.D.
DCR# 930, REV. 3, UPDATED FRAME, BELT GUARD & COMPANY LOGO, 10/21/2021, I.D.
DCR# 997, REV. 4, UPDATED FRAME, BELT GUARD, BOM, 01/28/2023, I.D.

PROPRIETARY AND CONFIDENTIAL
THE INFORMATION CONTAINED IN THIS DRAWING IS THE SOLE PROPERTY OF FRUITLAND MANUFACTURING. ANY REPRODUCTION IN PART OR AS A WHOLE WITHOUT THE WRITTEN PERMISSION OF FRUITLAND MFG. IS PROHIBITED.

	NAME	DATE	 324 Leaside Avenue Stoney Creek, Ontario, CANADA L8E 2N7 Phone: (905) 662-6552 Fax: (905) 662 9875	
CREATED	Z.D	05/14/2019	TITLE: ELIM DH870LUF Hatz BOM	
CHECKED	K.A.	05/14/2019		
UNLESS OTHERWISE SPECIFIED: DIMENSIONS ARE IN INCHES TOLERANCES: FRACTIONAL OR .X = ±.015 .XX = ±.010 .XXX = ±.005			DWG. NO. ELIM DH870LUF BOM	REV 4
MATERIAL	--	SCALE: 1:18	WEIGHT:--	SHEET: 2 OF 2

ELIM DH870LUF DIESEL HATZ DIMS.

CUSTOMER COPY

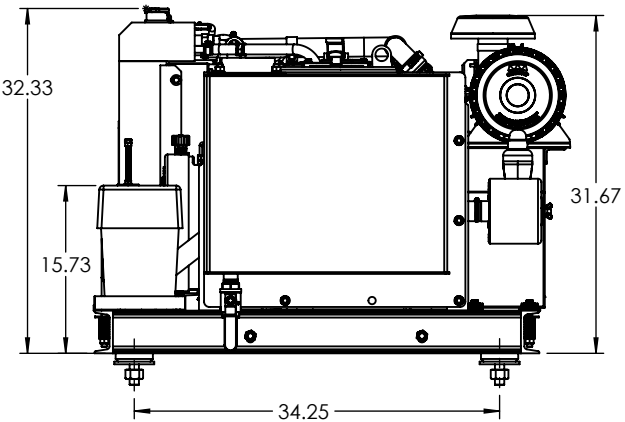
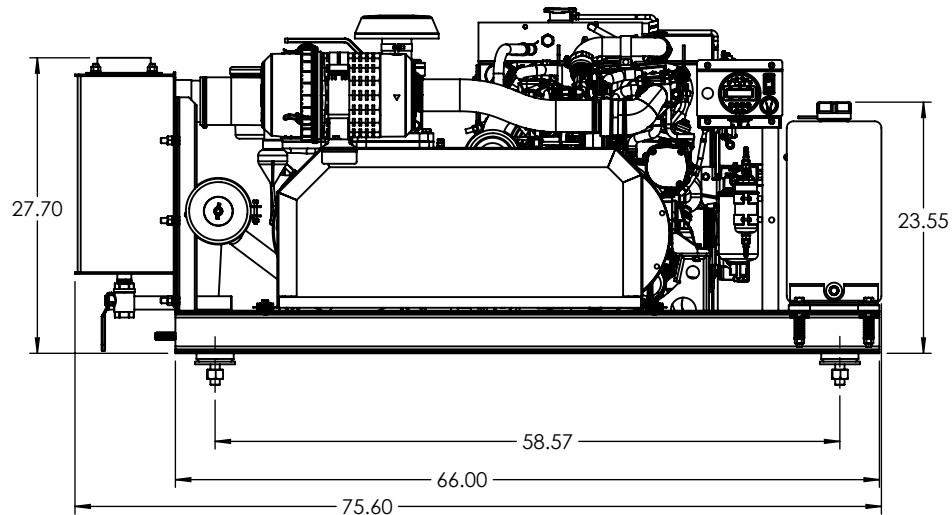
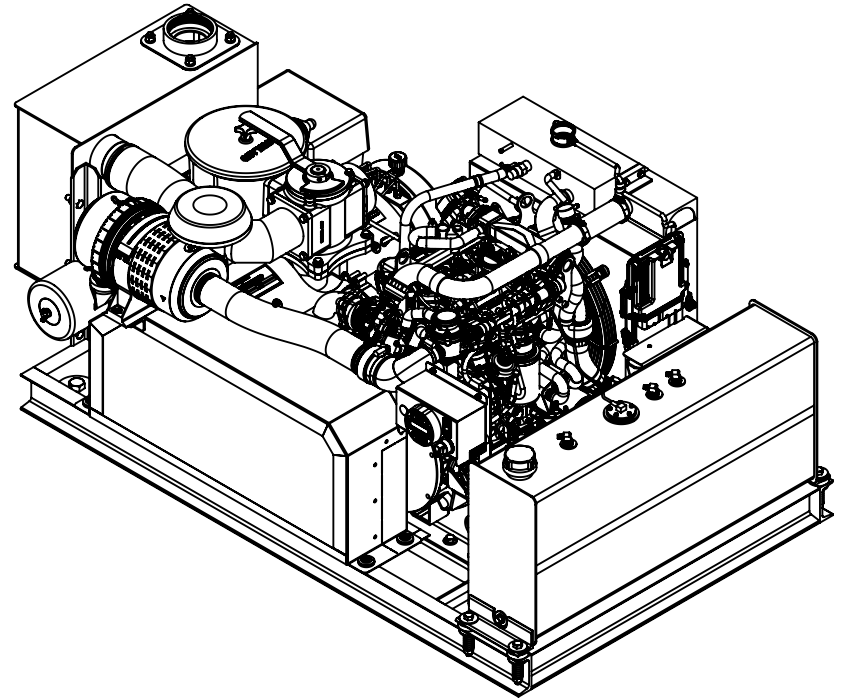
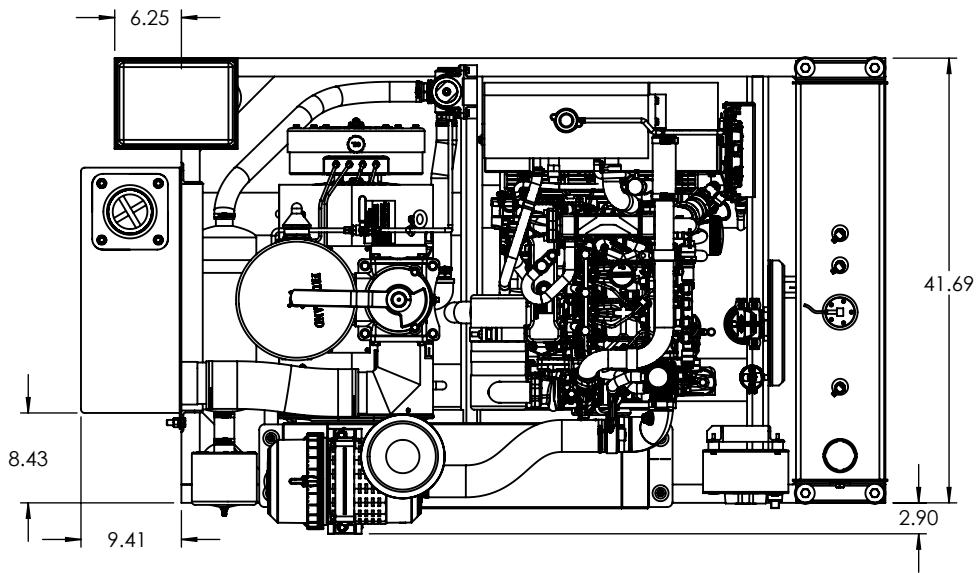

PART # ELIM DH870LUF

DCR# 874, REV. 1, UPDATED BOM, 10/29/2020, Z.D.
DCR# 916, REV. 2, UPDATED FRAME & BOM, 08/23/2021, Z.D.
DCR# 932, REV. 3, UPDATED FRAME, BELT GUARD & COMPANY LOGO, 12/21/2021, Z.D.
DCR# 997, REV. 4, UPDATED FRAME, BELT GUARD, BOM, 01/26/2023, Z.D.

PROPRIETARY AND CONFIDENTIAL
THE INFORMATION CONTAINED IN THIS DRAWING IS THE SOLE PROPERTY OF FRUITLAND MANUFACTURING. ANY REPRODUCTION IN PART OR AS A WHOLE WITHOUT THE WRITTEN PERMISSION OF FRUITLAND MFG. IS PROHIBITED.

	NAME	DATE	 324 Leaside Avenue Stoney Creek, Ontario, CANADA L8E 2N7 Phone: (905) 662-6552 Fax: (905) 662-9875
CREATED	K.A.	03/18/2019	
CHECKED			TITLE: ELIM DH870LUF Hatz Dims
UNLESS OTHERWISE SPECIFIED: DIMENSIONS ARE IN INCHES TOLERANCES: FRACTIONAL OR .X = ±.015 .XX = ±.010 .XXX = ±.005			DWG. NO. ELIM DH870LUF-DIM
MATERIAL	--	SCALE: 1:18	WEIGHT:--
			REV 4