

VOL. TOTAL: 623 L (164 GAL)
 WATER CAPACITY: 445 L (117.5 GAL)

FRUITLAND LIQUID RING PUMP START-UP INSTRUCTIONS

Important:

Please read liquid ring pump installation, operation, and maintenance manual to understand pump operation.

Before Start-up:

- 1- Check liquid level in the tank #1, add up to the fill line through filling connection #6 if required.
- 2- Check liquid level in pump through hose location #2. It is important to have the liquid up to the center line of the pump.
- 3- Use valve #3 to add liquid to the vacuum pump.

Start-up:

- 1- Start the pump and within 20 sec of starting the pump, open the liquid feed valve #3 to start feeding liquid to the pump. Failure to open the valve will result in serious pump damage.
- 2- Proceed with regular pumping operation.

Shut down:

- 1- Before shutting off the pump, turn off the liquid supply valve #3. There shouldn't be more than 10 sec delay between the two steps. It is important to shut off the water when the pump is not running to prevent the flooding of pump, diverter, and other parts of the system.

Install drain valve #5 at the bottom of the pump to drain a flooded pump.

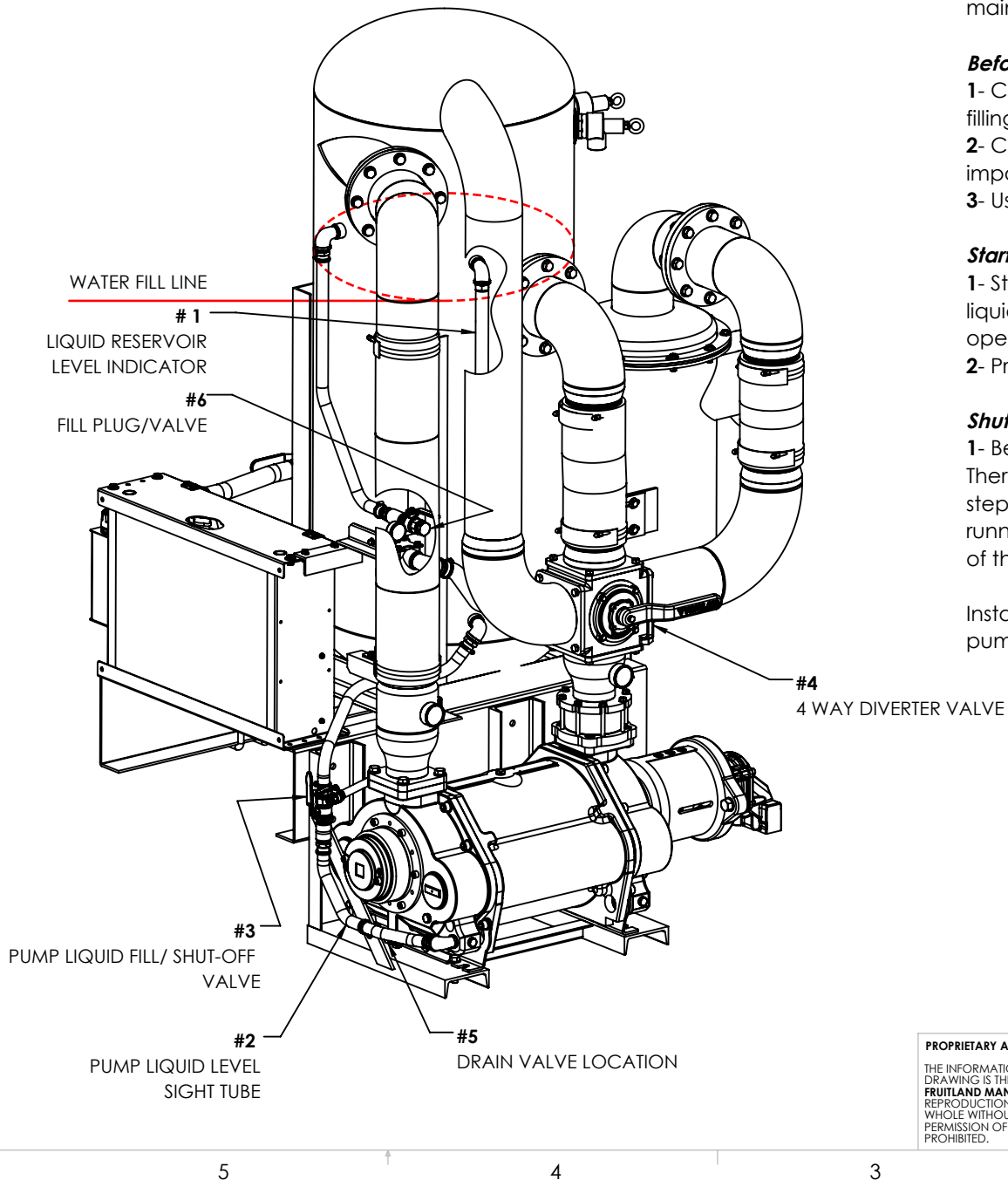

REV. P1, REMOVED PR VALVE MANIFOLD ASSM, RESERV. & SEC. DESIGN UPDATED, 05/14/2024, Z.D.

	NAME	DATE	 324 Leaside Avenue Stoney Creek, Ontario, CANADA L8E 2N7 Phone: (905) 662-6552 Fax: (905) 662 9875	
CREATED	Z.D.	03/20/24		
CHECKED	K.A.	03/20/24	TITLE:	
UNLESS OTHERWISE SPECIFIED: DIMENSIONS ARE IN INCHES TOLERANCES: FRACTIONAL OR .X = ±.015 .XX = ±.010 .XXX = ±.005			TITLE: ELIM LR2500R STARTUP OPERATION	
MATERIAL		--	DWG. NO. ELH-25R-STARTUP	REV P1
		SCALE: 1:18	WEIGHT:--	

PROPRIETARY AND CONFIDENTIAL
 THE INFORMATION CONTAINED IN THIS DRAWING IS THE SOLE PROPERTY OF FRUITLAND MANUFACTURING. ANY REPRODUCTION IN PART OR AS A WHOLE WITHOUT THE WRITTEN PERMISSION OF FRUITLAND MFG. IS PROHIBITED.