

FRUITLAND

TRUCK MASTER 2500

Fruitland Truck Master pumps, powered by Samson Pumps are the only safe option for pumping hydrocarbons and other flammable or hazardous materials due to the impeller operating in an intermediate fluid. These pumps also offer high airflow with very low noise levels.

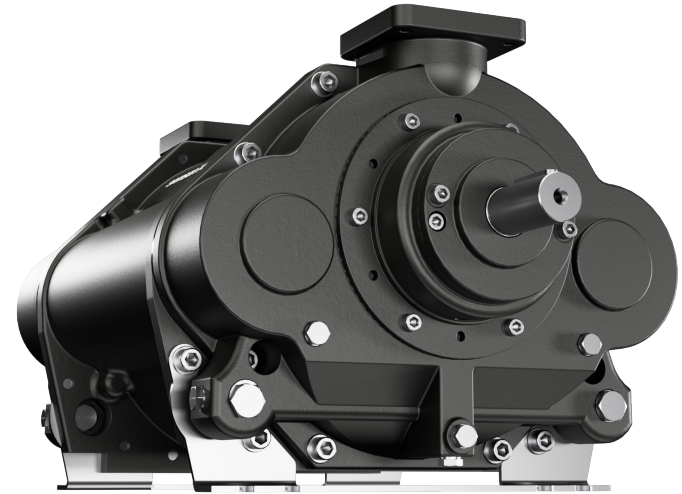

FEATURES

- Low Noise
- High Resistance to Corrosion
- Zero Emissions
- Zero Risk of Spark
- Low Maintenance
- Integrated Water Systems

APPLICATION PERFORMANCE

The Truck Master 2500 pump performs best with 5" hoses. 3" and 4" hoses can be used with a reduced RPM, and hoses larger than 5" can be used, but this is recommended for fluid lifts only.

- Max RPM: 1500
- CFM: 1451
- BHP Requirement at Max Pressure: 116
- Noise Level @ 23ft - 63 db(A)
- Water Consumption: 1 GAL/h at 68°F @ 80% Vacuum
- Weight: 708 Lbs
- 25.5 in-Hg Continuous Operation



