

FRUITLAND BOOM SWIVEL ROTATING SEAL BEARINGS

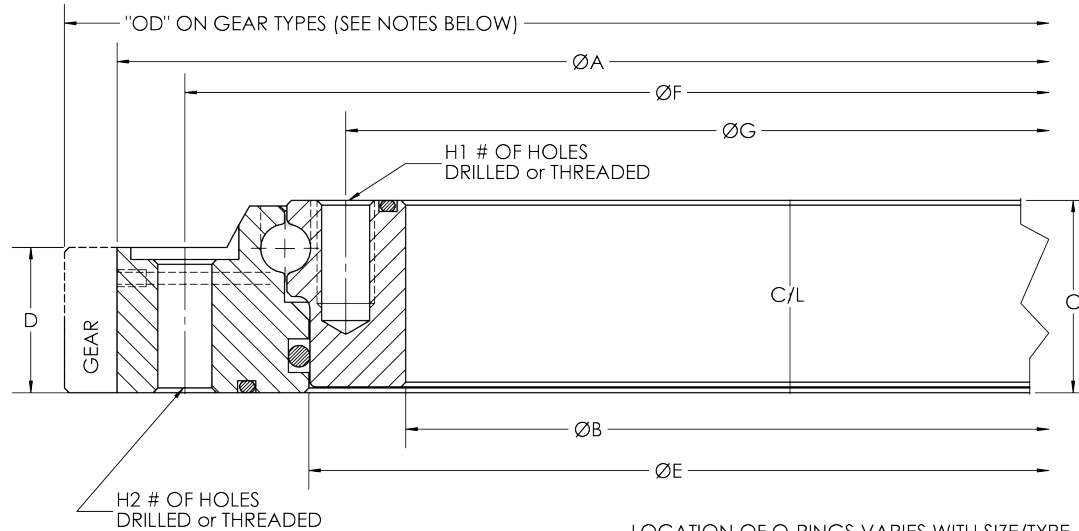

LOCATION OF O-RINGS VARIES WITH SIZE/TYPE
 MAX. RECOMMENDED RACEWAY VELOCITY 50FT/MIN

SIZE & TYPE	"OD" or $\varnothing A$	$\varnothing B$	C	D	$\varnothing E$	$\varnothing F$	$\varnothing G$	H1 # of Holes @ Drill Size or Thread	H2 # of Holes @ Drill Size or Thread	CAPACITIES (kN-m / lbf-ft)
BS4"	9.00	4.00	1.20	1.13	6.75	8.00	5.00	6 @ 9/16NC	6 @ 1/2 NC	2.34 / 1,725
BS6"(6)	13.00	6.25	3.50	N/A	N/A	9.50	9.50	8 @ 3/4 NC	8 @ 3/4 NC	13.80 / 10,178
BS8"	14.00	7.88	2.00	1.50	10.50	12.60	9.25	12 @ 1/2 NC	12 @ 9/16 NC	9.53 / 7,028
BS8"G	15.12	7.88	2.00	1.50	10.50	12.60	9.25	12 @ 1/2 NC	12 @ 9/16 NC	9.53 / 7,028
BS8"PW	11.50	8.33	3.38	N/A	N/A	N/A	N/A	N/A	N/A	1.50 / 1,106
BS10"	16.25	10.00	2.00	1.63	12.77	15.00	11.38	12 @ 1/2 NC	16 @ 9/16 NC	11.70 / 8,630
BS10"G	17.16	10.00	2.00	1.63	12.77	15.00	11.38	12 @ 1/2 NC	16 @ 9/16 NC	11.70 / 8,630
10WDS*	17.60	10.00	3.28	N/A	13.00	15.00	11.38	23 @ 5/8 NC	16 @ 5/8 NC	30.30 / 22,348
BS12"	20.40	12.00	2.20	1.75	16.36	19.29	13.07	24 @ 5/8 NC	12 @ 7/8 NC (on 16er DIV.)	40.30 / 29,723
BS12"G	21.26	12.00	2.20	1.75	16.36	19.29	13.07	24 @ 5/8 NC	12 @ 3/4 NC (on 16er DIV.)	40.30 / 29,723
13WDS*	21.80	12.88	3.38	N/A	16.64	18.88	14.38	20 @ 3/4 NC	20 @ 3/4 NC	54.67 / 40,322
BS17"	25.50	17.09	2.20	1.75	21.48	24.41	18.19	14 @ 3/4 NC	10 @ 51/64	45.30 / 33,411
BS17"G	25.21	17.09	2.20	1.75	21.48	23.23	18.19	14 @ 3/4 NC	14 @ 3/4 NC	48.00 / 35,402
BS17"HC	25.50	17.09	2.20	1.75	21.48	24.41	18.19	REQUEST HOLE PATTERN INFORMATION		72.60 / 53,546
BS17"GHC	25.21	17.09	2.20	1.75	21.48	23.23	18.19			72.60 / 53,546
GV17	25.51	17.09	2.20	1.75	21.48	24.41	18.19	14 @ 3/4 NC	10 @ 3/4 NC	45.30 / 33,411

NOTES:

- *Above section view does not represent a worm drive bearing.
- CAPACITIES are calculated using SAE GR. 8 Fasteners (Min. Tensile 150,000 psi)
- Use GASKETS on INNER RINGS of BS12", BS12"G, BS17"G, BS17"HC, BS17"GHC & GV17, if used for vacuum or pressure.
- BS 6" is constructed to accommodate 6" & 6" Standard 150 # Flanges
- BS 8"PW has NO BOLTS and is for WELDING 8" Sched. 10 Pipe on each side. (Request Information Sheet)
- BS 8"G (Gear Type): 94 Teeth, MOD. 4, use with OPTIONAL 15 or 18 Teeth Pinions
- BS 10"G (Gear Type): 107 Teeth, MOD. 4, use with OPTIONAL 15 or 18 Teeth Pinions
- BS 12"G (Gear Type): 106 Teeth, MOD. 5, use with OPTIONAL 16 Teeth Pinions
- BS 17"G (Gear Type): 105 Teeth, MOD. 6, use with OPTIONAL 17 Teeth Pinions

General information only.

Fruitland Manufacturing reserves the right to make changes without notice. FM-BS-07/13 - Rev. 2